

ABOYTES MFG.

Abrasive Blasting Equipment & Dust Collectors

Dry Suction Blast Cabinet

**Made In The
U.S.A.**



Used in applications such as:

- **Cleaning**
 - Precision parts
 - Semiconductor parts
 - Metal castings
- **Preparing**
 - Surface for Painting
 - Plating
- **Removing**
 - Heat treated Scales
 - Carbon Deposits
 - Oxides
 - Paint
- **Finishing**
 - Automotive
 - Arts and Crafts
 - Decorating
 - Etching
 - Glass
 - Removal of Scale

And many more.....

This machine can be used with all available abrasives on the market.

- Aluminum Oxide, Glass Bead, Plastic, Garnet Grain, Walnut shell and many others.....



A Good Dust Collector is the best friend of your cabinet



Big loading capacity for greater work production

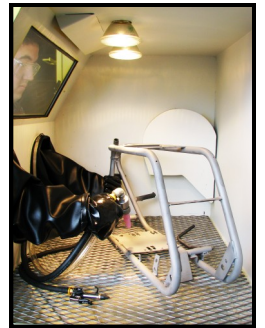

Built-in media separator to reduce good abrasive consumption

Model: ADS 36

WWW.ABOYTESMFG.COM

37580 Enterprise Crt. Suite A ~ Newark, Ca. 94560 ~ Tel: 510.792.2875 ~ Fax: 510.792.2125

ABOYTES MFG. DRY SUCTION SERIES

Model	Work Area Dimensions	Floor Dimensions	Work Stations	Door Opening Right Side	Spot Lights	Dust Collector	Motor	Dust Collector CFM	Electrical	Tubular Filter Bags	Filter Area Sq. Ft.	Shipping Weight
ADS 36	W 36" D 30" H 30"	A 87" B 63" C 32"	1	D:27.5" E:21.5" F:13" G:16.5" H:28"	2	DC9	3/4 hp. 115/208-230 1 phase	450	1 phase 110 voltage 1 switch controls Lights/motor	9	45	*
ADS 4830	W 48" D 30" H 30"	A 87" B 70" C 32"	1	D:27.5" E:21.5" F:13" G:16.5" H:28"	4	DC9	3/4 hp. 115/208-230 1 phase	450	1 phase 110 voltage 1 switch controls Lights/motor	9	45	*
ADS 4836	W 48" D 36" H 36"	A 87" B 70" C 37"	1	D:32.5" E:26" F:12.5" G:21.5" H:33"	4	DC9	3/4 hp. 115/208-230 1 phase	450	1 phase 110 voltage 1 switch controls Lights/motor	9	45	*

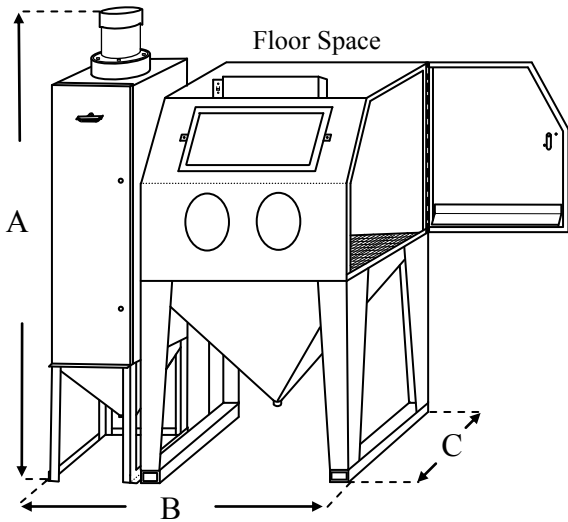

Features :

- Fabricated with 14 gauge steel Continuously welded
- Built in Cyclone to separate abrasive from waste debris
- Right side loading on standard models
- Full size door opening with abrasive spill proof
- Large window viewing area 25" X 11"
- Exterior laminate automobile safety glass
- Regular inside glass, easy to replace with safety clips
- High flow air regulator and valves
- Air pressure booster and moisture separator
- Electrical toggle switch to control lights and motor

Maintains 100% of its value over the years.

Heavy-Duty:

- Full length neoprene gloves and sleeves
- Brass foot control and safety guard
- Blasting gun assembly
- Expanded metal work bench

Engineered for many years of trouble-free and reliable service.

- No** Rivets
- No** Spot Welds
- No** Caulking Unions
- No** Shop/Barrel Vacuum Dust Collector

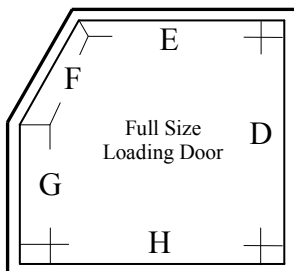

Safe & Easy window frame removal to replace inside glass



High flow air regulator with pressure booster and moisture separator

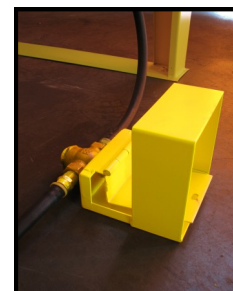

High air flow foot control valve & safety guard Pedal



Easy removal of waste material

Air Consumption

NOZZLE ORIFICE	AIR JET	AIR (PSI)	40	50	60	70	80	90	100
1/4"	1/8"	(CFM) Req.	12	15	17	19	21	23	26
3/8"	3/16"		26	30	35	40	45	49	54
1/2"	1/4"		45	53	60	67	74	81	87

This table is to be used as reference only.

Distributed By:

